



### Compressor Selection: Semi-hermetic Reciprocating Compressors

#### Input Values

Compressor model Mode	(4T-8.2Y) Refrigeration and Air conditioning	Suction gas temperature Operating mode	20,00 °C Auto
Refrigerant Reference temperature Liq. subc. (in condenser)	R404A Dew point temp. 0 K	Power supply Capacity Control Useful superheat	400V-3-50Hz 100% 100%

#### Result

Q [W]	Cooling capacity	COP [-]	COP/EER
Q* [W]	Cooling capacity *	COP* [-]	COP/EER *
P [kW]	Power input	m [kg/h]	Mass flow
I [A]	Current	Op.	Operating mode
Qc [W]	Condenser Capacity	th [°C]	Discharge gas temp. w/o cooling

tc	to	-5°C	-10°C	-15°C	-20°C	-25°C	-30°C	-35°C	-40°C
30°C	Q [W]	31638	26125	21358	17250	13728	10727	8186	6052
	Q* [W]	31638	26125	21358	17250	13728	10727	8186	6052
	P [kW]	8,01	7,58	7,10	6,58	6,02	5,41	4,77	4,10
	I [A]	13,84	13,19	12,47	11,69	10,86	10,00	9,11	8,22
	Qc [W]	39647	33704	28459	23829	19744	16139	12959	10151
	COP [-]	3,95	3,45	3,01	2,62	2,28	1,98	1,72	1,48
	COP* [-]	3,95	3,45	3,01	2,62	2,28	1,98	1,72	1,48
	m [kg/h]	795	650	527	423	334	260	197,5	145,5
	Op.	Standard	Standard	Standard	Standard	Standard	Standard	Standard	Standard
	th [°C]	68,8	75,4	82,5	90,4	99,2	109,3	120,8	134,4
40°C	Q [W]	27147	22336	18167	14571	11486	8857	6632	4767
	Q* [W]	27147	22336	18167	14571	11486	8857	6632	4767
	P [kW]	9,29	8,64	7,94	7,20	6,42	5,61	4,77	3,92
	I [A]	15,81	14,81	13,74	12,62	11,46	10,28	9,11	8,00
	Qc [W]	36440	30979	26110	21771	17906	14466	11407	8689
	COP [-]	2,92	2,58	2,29	2,02	1,79	1,58	1,39	1,22
	COP* [-]	2,92	2,58	2,29	2,02	1,79	1,58	1,39	1,22
	m [kg/h]	769	625	504	401	314	241	179,4	128,4
	Op.	Standard	Standard	Standard	Standard	Standard	Standard	Standard	Standard
	th [°C]	79,9	86,6	93,9	101,8	110,6	120,4	131,5	0
50°C	Q [W]	--	18263	14764	11739	9139	6922	5045	3471
	Q* [W]	--	18263	14764	11739	9139	6922	5045	3471
	P [kW]	--	9,70	8,72	7,73	6,75	5,77	4,81	3,88
	I [A]	--	16,43	14,92	13,42	11,94	10,51	9,16	7,94
	Qc [W]	--	27958	23479	19468	15885	12692	9858	7351
	COP [-]	--	1,88	1,69	1,52	1,35	1,20	1,05	0,89
	COP* [-]	--	1,88	1,69	1,52	1,35	1,20	1,05	0,89
	m [kg/h]	--	591	473	373	288	217	157,0	107,6
	Op.	--	Standard	Standard	Standard	Standard	Standard	Standard	Standard
	th [°C]	--	99,3	106,6	114,6	123,7	134,4	0	0

-- No calculation possible (see message in single point selection)

\*According to EN12900 (20°C suction gas temp., 0K liquid subcooling)

#### Application Limits 100%

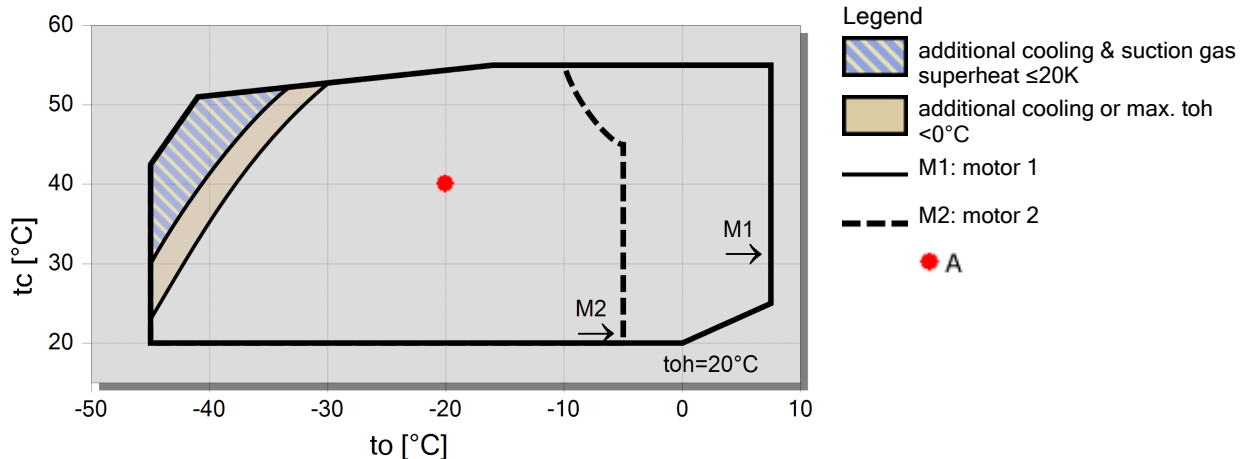



## Technical Data: (4T-8.2Y)

### Dimensions and Connections

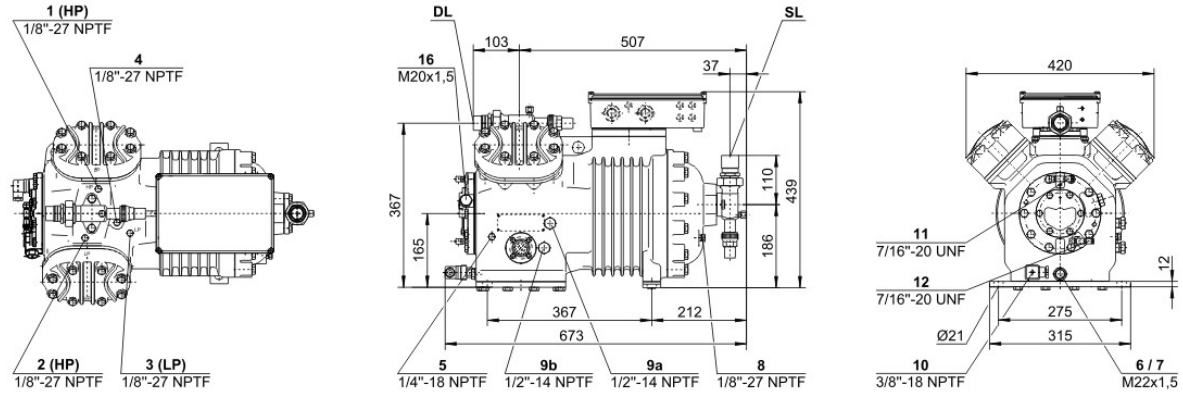

### Technical Data

#### Technical Data

Displacement (1450 RPM 50Hz)	39,36 m³/h
Displacement (1750 RPM 60Hz)	47,50 m³/h
No. of cylinder x bore x stroke	4 x 60 mm x 40 mm
Weight	138 kg
Max. pressure (LP/HP)	19 / 28 bar
Connection suction line	35 mm - 1 3/8"
Connection discharge line	28 mm - 1 1/8"
Connection cooling water	R 1/2"
Oil type R134a/R407C/R404A/R507A/R407A/R407F	tc<55°C: BSE32 / tc>55°C: BSE55 (Option)
Oil type R22 (R12/R502)	B5.2 (Standard)
Oil type R290/R1270	SHC226E (Standard)

#### Motor data

Motor voltage (more on request)	380-420V PW-3-50Hz
Max operating current	17.0 A
Winding ratio	50/50
Starting current (Rotor locked)	49.0 A Y / 81.0 A YY
Max. Power input	10,3 kW

#### Extent of delivery (Standard)

Motor protection	SE-B2
Enclosure class	IP54 (Standard), IP66 (Option)
Vibration dampers	Standard
Oil charge	3,00 dm³

#### Available Options

Discharge gas temperature sensor	Option
Start unloading	Option
Capacity control	100-50% (Option)
Additional fan	Option
Water-cooled cylinder heads	Option
CIC System	Option
Oil service valve	Option
Crankcase heater	100 W (Option)
Oil pressure monitoring	MP54 (Option), Delta-PII (Option, not for R290/R1270)

#### Sound measurement

Sound power level (-10°C / 45°C)	77,5 dB(A) @ 50Hz
Sound power level (-35°C / 40°C)	83,5 dB(A) @ 50Hz
Sound pressure level @ 1m (-10°C / 45°C)	69,5 dB(A) @ 50Hz
Sound pressure level @ 1m (-35°C / 40°C)	75,5 dB(A) @ 50Hz



## Compressor Selection: Semi-hermetic Reciprocating Compressors

### Input Values

Compressor model Mode	(2CC-3.2Y) Refrigeration and Air conditioning	Suction gas temperature Operating mode	20,00 °C Auto
Refrigerant Reference temperature Liq. subc. (in condenser)	R404A Dew point temp. 0 K	Power supply Capacity Control Useful superheat	400V-3-50Hz 100% 100%

### Result

Q [W] Qu* [W] P [kW] I [A] Qc [W]	Cooling capacity Evaporator capacity Power input Current Condenser Capacity	COP [ - ] m [kg/h] Op. th [°C]	COP/EER Mass flow Operating mode Discharge gas temp. w/o cooling
---	---	---	---

tc	to	-5°C	-10°C	-15°C	-20°C	-25°C	-30°C	-35°C	-40°C
30°C	Q [W]	12468	10290	8404	6779	5384	4193	3184	2334
	Qu* [W]	12468	10290	8404	6779	5384	4193	3184	2334
	P [kW]	3,33	3,15	2,95	2,72	2,48	2,21	1,93	1,64
	I [A]	6,15	5,91	5,64	5,35	5,04	4,72	4,41	4,12
	Qc [W]	15795	13442	11354	9502	7859	6404	5116	3977
	COP [ - ]	3,75	3,26	2,85	2,49	2,17	1,90	1,65	1,42
	m [kg/h]	313	256	207	166,0	131,1	101,6	76,8	56,1
	Op.	Standard	Standard	Standard	Standard	Standard	Standard	Standard	Standard
	th [°C]	70,7	77,5	85,0	93,1	102,2	112,3	124,1	138,0
	40°C	Q [W]	10508	8649	7036	5642	4443	3418	2548
Qu* [W]		10508	8649	7036	5642	4443	3418	2548	1814
P [kW]		3,85	3,58	3,29	2,98	2,65	2,32	1,97	1,62
I [A]		6,88	6,50	6,10	5,68	5,26	4,85	4,45	4,10
Qc [W]		14363	12232	10326	8621	7096	5734	4518	3434
COP [ - ]		2,73	2,41	2,14	1,89	1,67	1,48	1,29	1,12
m [kg/h]		297	242	195,1	155,2	121,4	92,9	68,9	48,9
Op.		Standard	Standard	Standard	Standard	Standard	Standard	Standard	Standard
th [°C]		82,7	89,7	97,4	105,8	115,1	125,6	137,9	0
50°C		Q [W]	8594	7053	5711	4548	3544	2685	1954
	Qu* [W]	8594	7053	5711	4548	3544	2685	1954	1336
	P [kW]	4,35	3,98	3,60	3,21	2,80	2,39	1,98	1,57
	I [A]	7,60	7,07	6,53	5,98	5,45	4,94	4,47	4,06
	Qc [W]	12942	11035	9311	7753	6347	5079	3937	2910
	COP [ - ]	1,98	1,77	1,59	1,42	1,26	1,12	0,98	0,85
	m [kg/h]	282	228	182,9	144,3	111,6	84,0	60,8	41,4
	Op.	Standard	Standard	Standard	Standard	Standard	Standard	Standard	Standard
	th [°C]	95,2	102,5	110,4	119,2	128,9	0	0	0

-- No calculation possible (see message in single point selection)

\*According to EN12900 (20°C suction gas temp., 0K liquid subcooling)

### Application Limits 100% Octagon

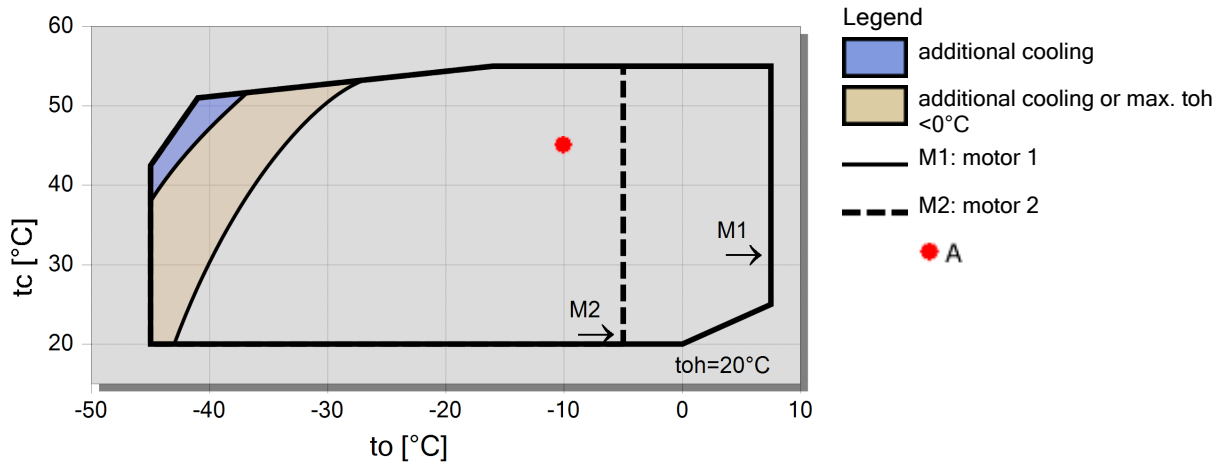

#### Legend

- additional cooling
- additional cooling or max. toh < 0°C
- M1: motor 1
- M2: motor 2
- A